

KIDS Electric scooter



User Manual

KIDS Electric scooter

Scout Jr.



Contents

Package Contents	02
Product Description	03
Product Installation	04
Charger Connection	07
How to Ride and Park	09
Ambient Light Control	10
Safety Instructions	12
Folding And Handling	13
Daily Maintenance	14
Product Parameter Table	16

1 Package Contents

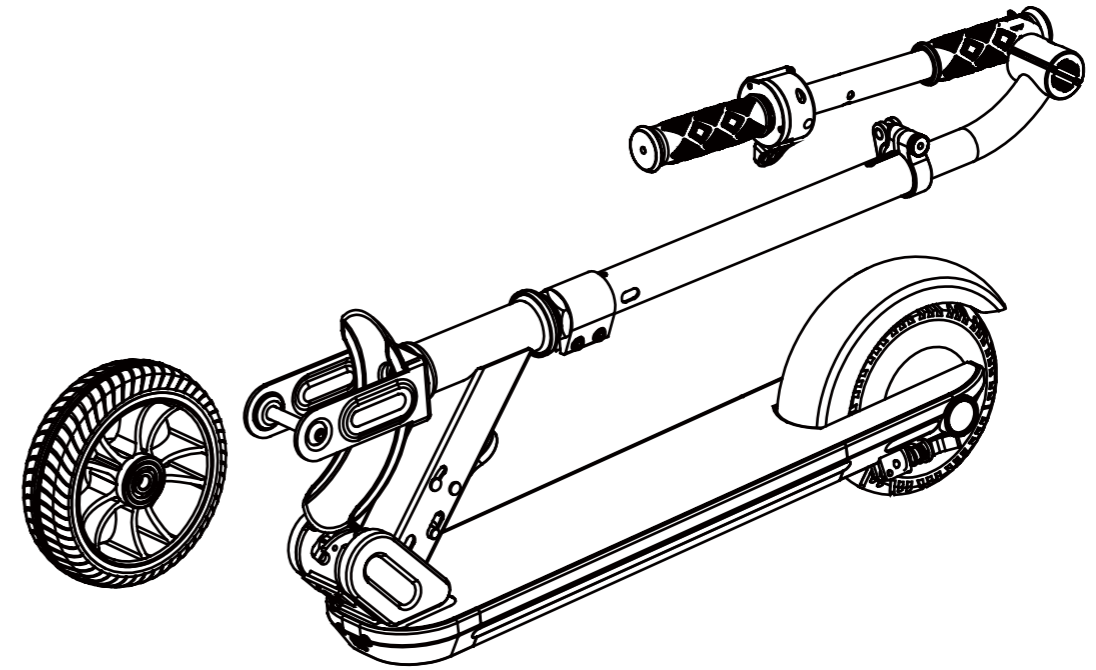

Accessories

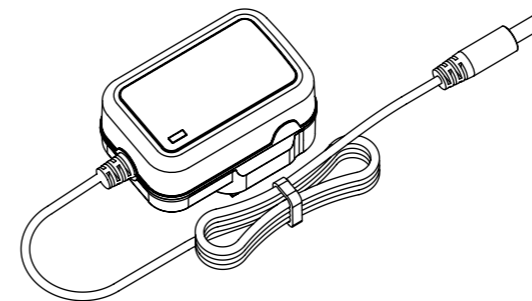

Charger



5mm inner hexagon wrench

The Scoot Jr. packaging box contains the following parts, if any are missing, please consult the seller:

- 01 E Scooter
- 02 Charger
- 03 Tool bag
- 04 user's manual
- 05 front wheel

2 Product Description

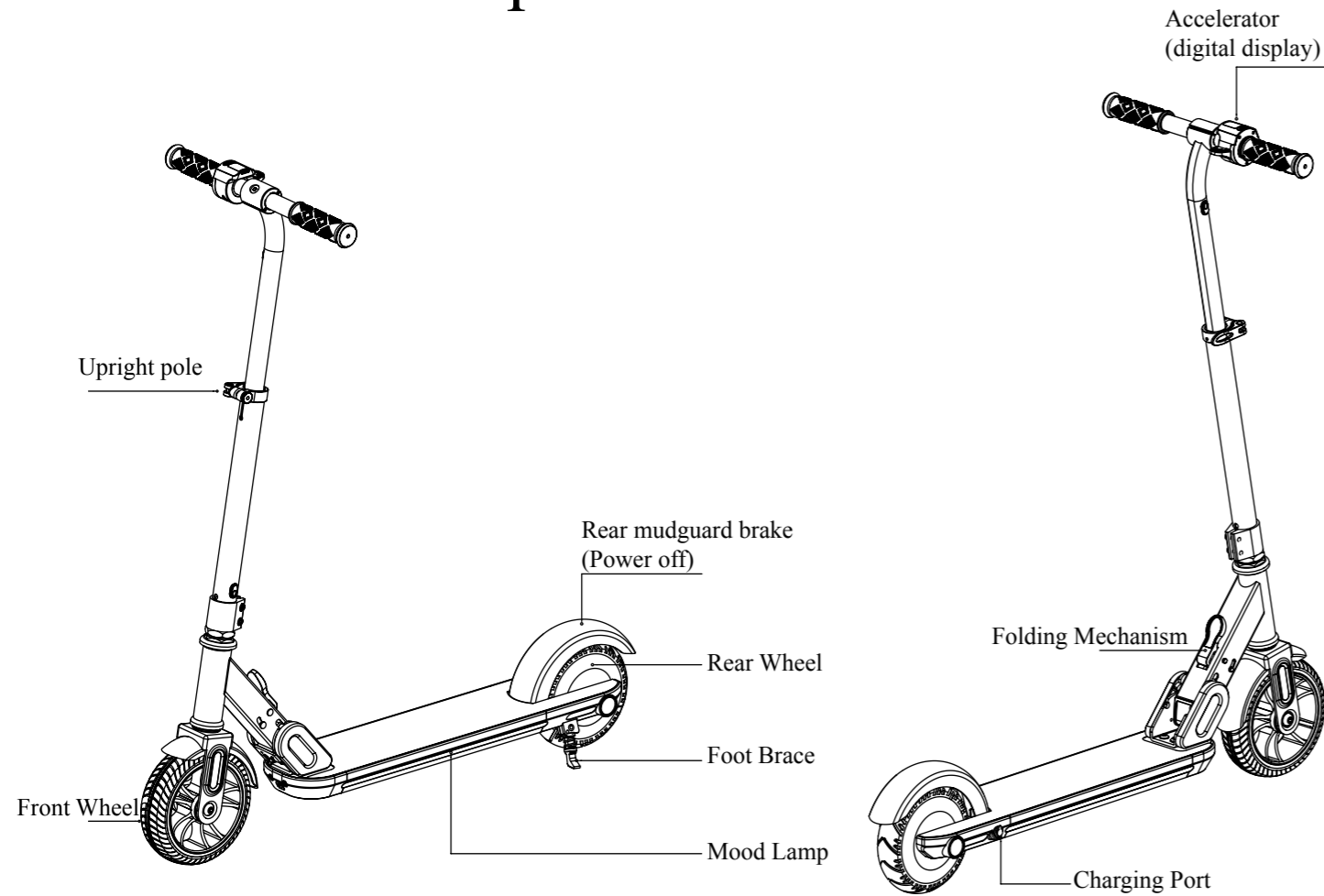

Multi-function code table

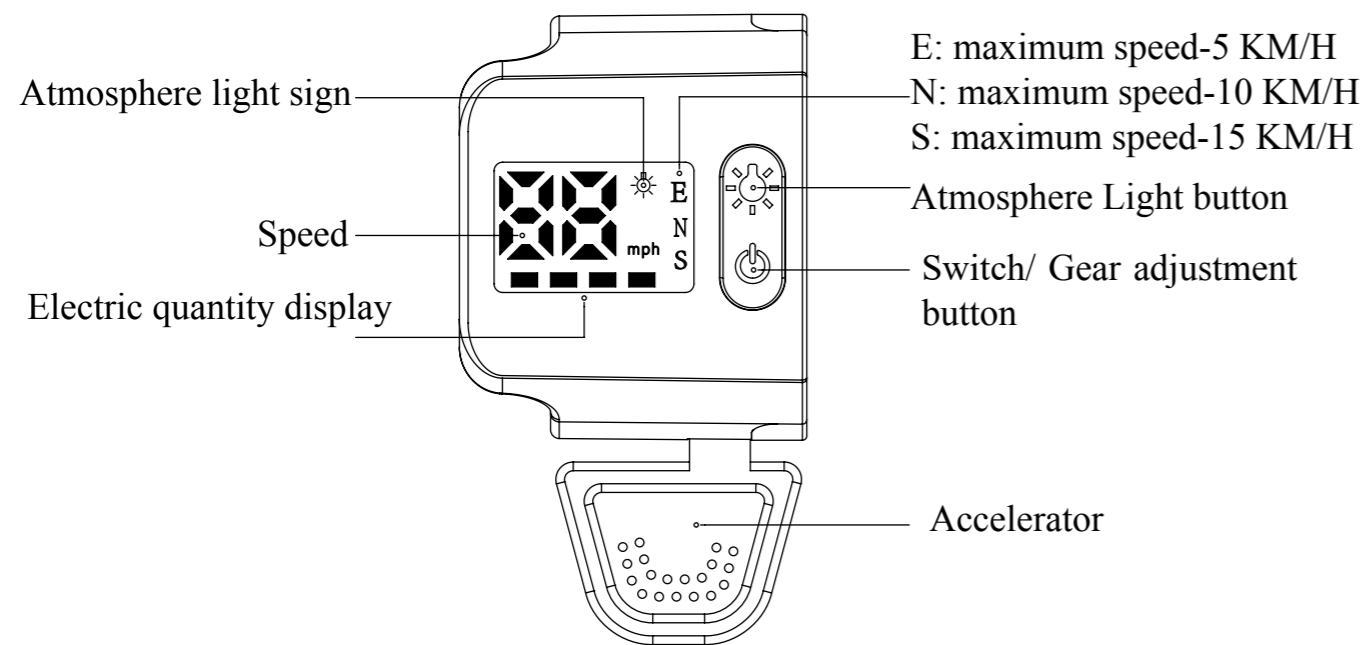

3 Product Installation

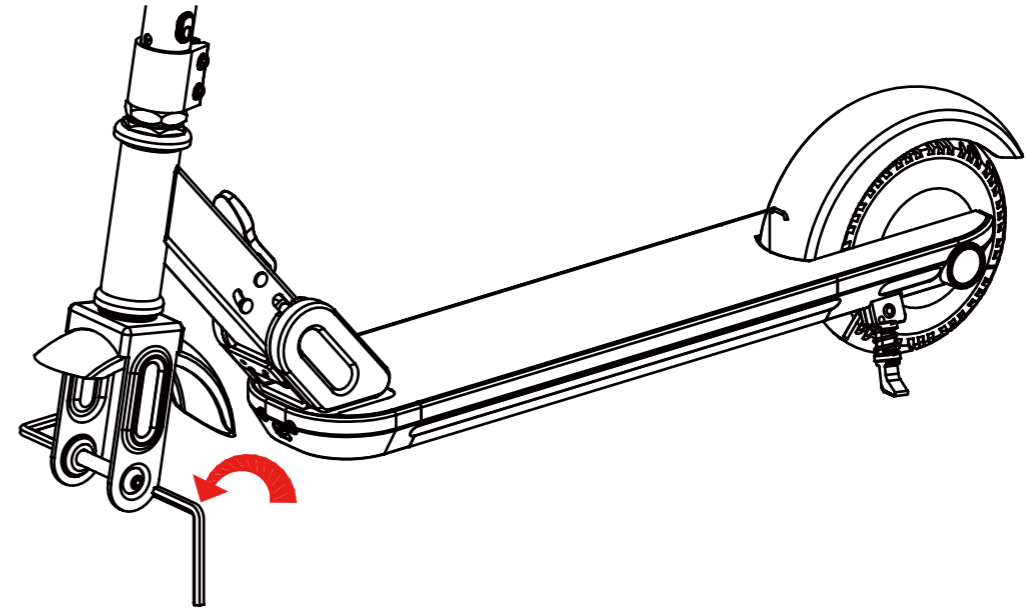

Use two 5mm hex keys to unscrew the screw on the front fork by turning it counterclockwise, then remove the spacer sleeve from the front fork.

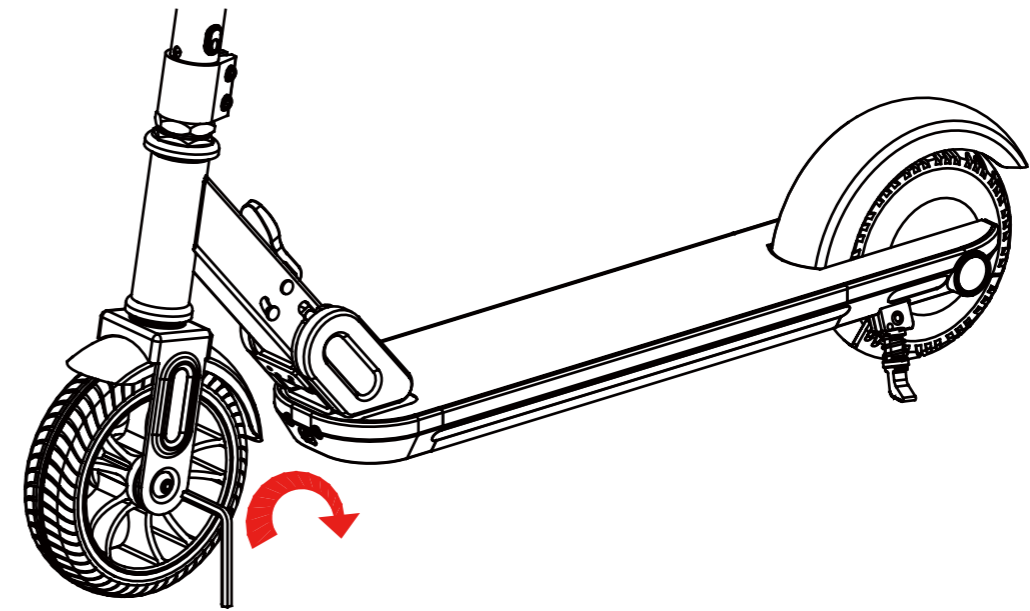

Insert the front wheel into the front fork, align the screw through the front fork and front wheel in that order, then turn the screw clockwise to secure and lock it in place.

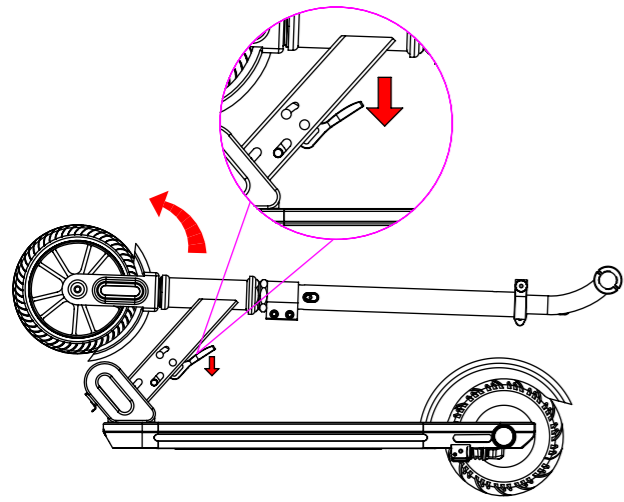

Set the scooter on a flat surface, then pull down the folding lever to unfold it



Insert the handle into the handle mounting bracket, then pass the screw through the hole in both the handle and the mounting bracket.

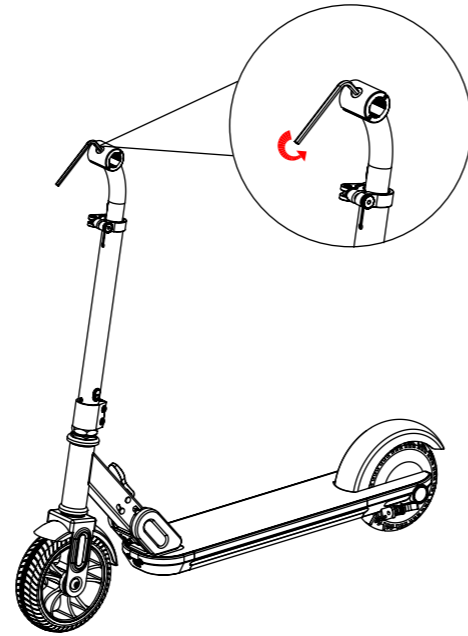

Use a 5mm hex wrench to secure and lock the handle in place



Turn the 5mm hex wrench clockwise to secure the handle mounting bracket.

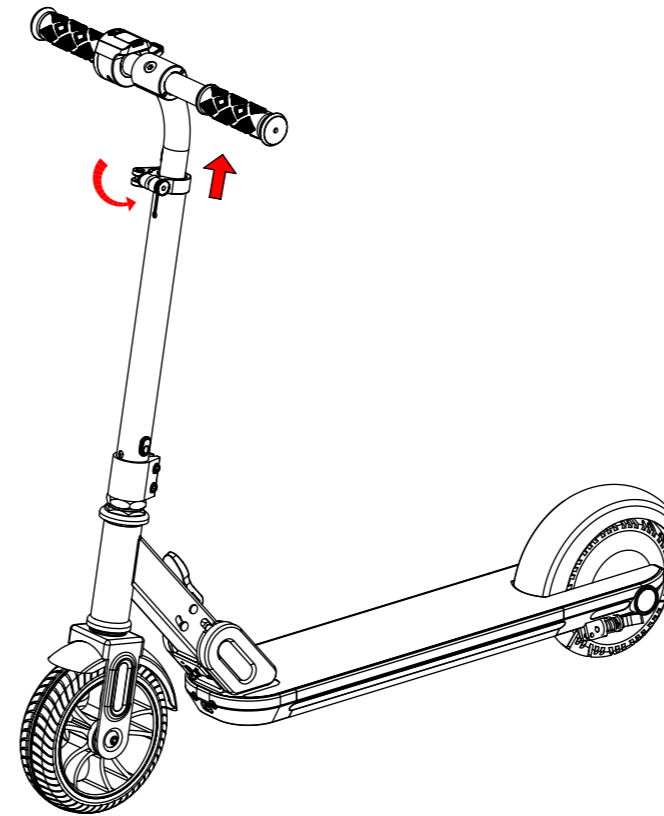

Adjust the handle height by loosening the quick-release lock and sliding the telescopic rod to the desired height. Once adjusted, re-tighten the lock to secure it, then quickly release it.

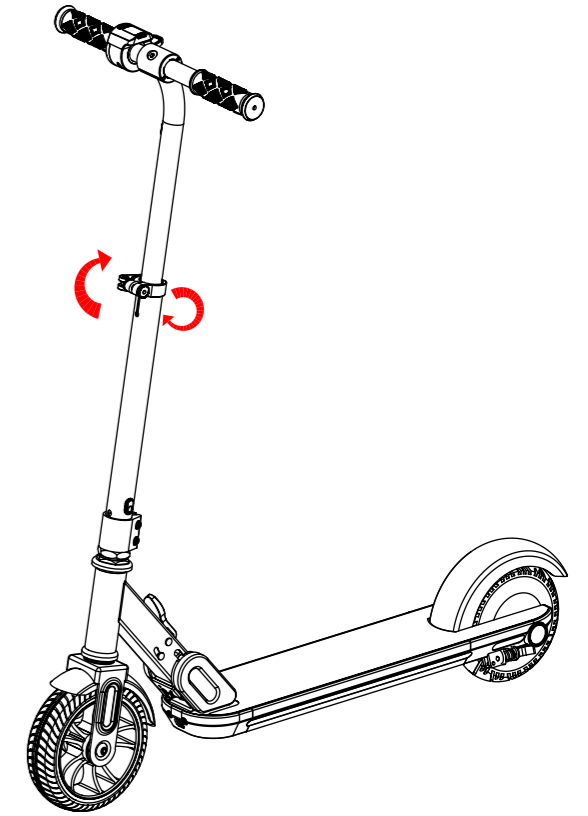

The tightness of the quick-release mechanism can be adjusted by manually tightening or loosening the inner hex bolts. Be careful not to overtighten. It can be easily opened and locked by hand, ensuring that the telescopic rod remains secure without sliding or shaking.

4 Charger Connection

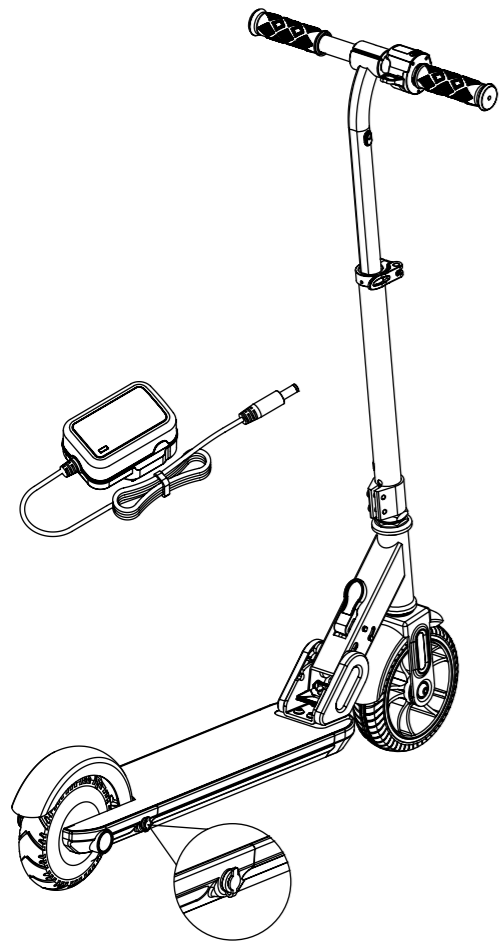

Note: Please use the original lithium battery charger that came with the scooter for indoor charging. Do not use non-original chargers or lead-acid battery chargers, to charge the scooter.

Before charging, ensure that the scooter's charging port is dry. If it is wet, wipe it clean before proceeding. Connect the charger's output terminal to the scooter's charging port, then plug the charger into a power source.

The charger's indicator light will turn red to show that the scooter is charging, and green indicates that charging is complete. At this point, unplug the charger to prevent prolonged charging, which can cause irreversible damage to the scooter's battery.

Once charging is finished, cover the scooter's charging port with the dust plug to prevent dust or water from entering the port and causing a short circuit during use.

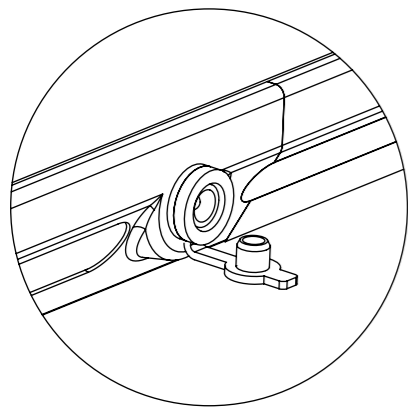

Remove the dust plug from the charging port

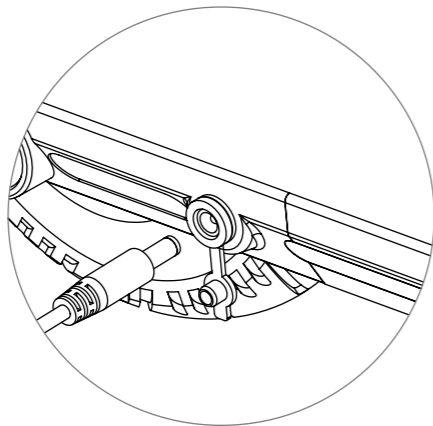

Plug in the charger

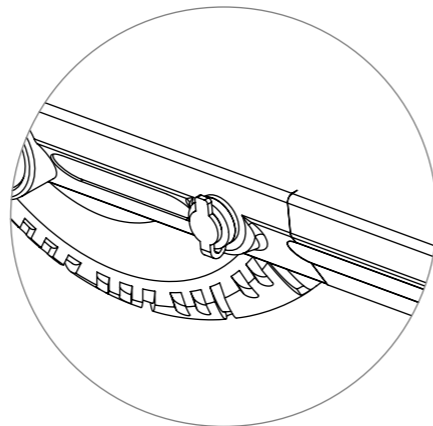

Cover the charging port with the dust plug after charging

5 How to Ride and Park

Before riding the scooter, please ensure you wear the necessary safety gear for your protection. Make sure you are proficient in operating the scooter.

It is advisable to wear comfortable, casual clothing and flat shoes, as high heels are not permitted to maintain flexibility in your movements.

You can practice riding on various terrains, but be sure to slow down when encountering unfamiliar surfaces. Never lift the scooter off the ground at any time. The scooter is intended as a supplementary mode of transportation primarily designed for flat roads. When riding on uneven terrain, reduce your speed and proceed cautiously.

While riding, keep your feet firmly on the scooter's pedals to avoid the risk of losing balance.

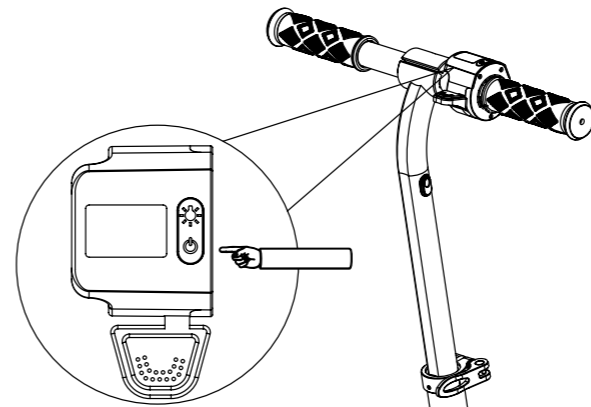

1. Press the power switch button and check if the power indicator light is on

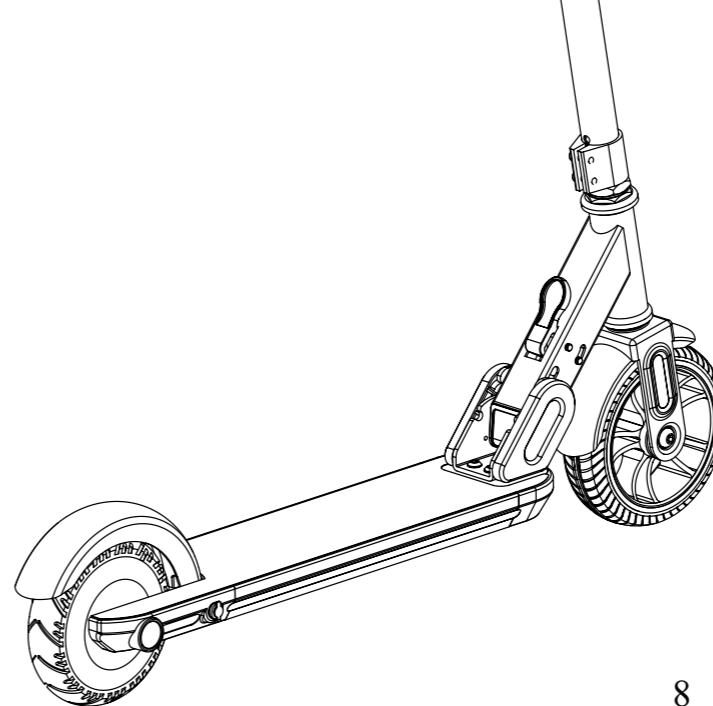

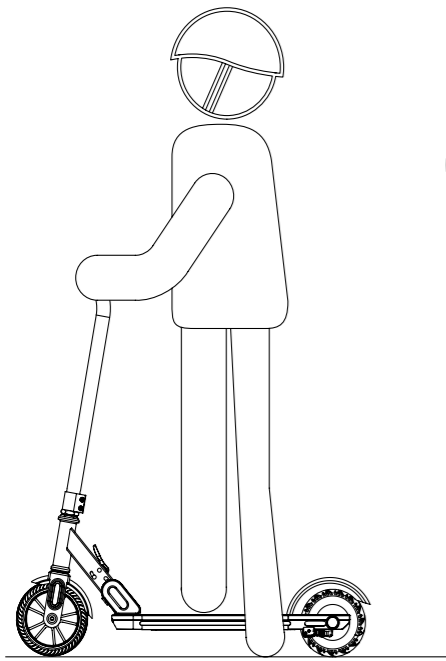

2. Place one foot on the footplate and push the scooter forward

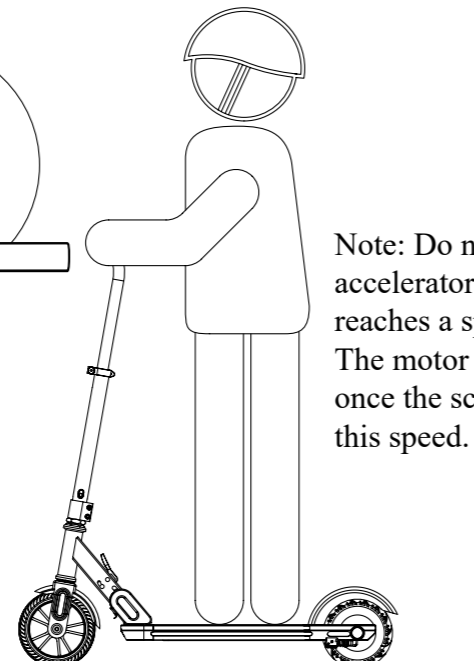
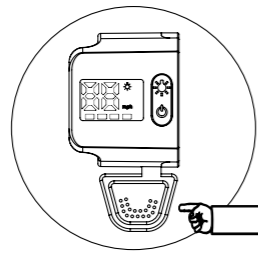

Note: Do not press the accelerator until the scooter reaches a speed of 3 km/h. The motor will only engage once the scooter has reached this speed.

3. Once the scooter reaches speed, press the accelerator.

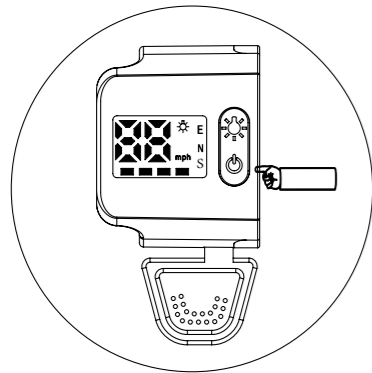

4. When you need to change speeds, come to a safe stop, then press the power switch button to switch gears. The maximum speed for E gear is 5 KM/H, for N gear is 10 KM/H, and for S gear is also 15 KM/H

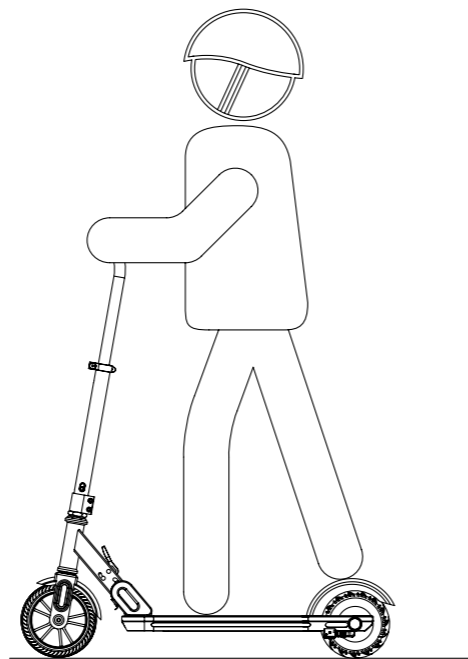

5. To stop, step on the rear wheel mudguard to apply friction for braking. The electronic brake will activate even without direct contact with the wheel.

6 Ambient Light Control

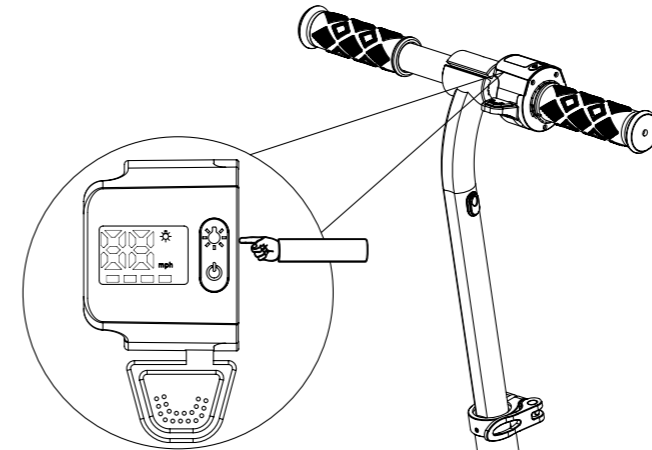

Press the power switch button to turn on the scooter and ensure that the power LED is illuminated. Briefly press the atmosphere light switch button on the accelerator to cycle through the different types of atmosphere lights.

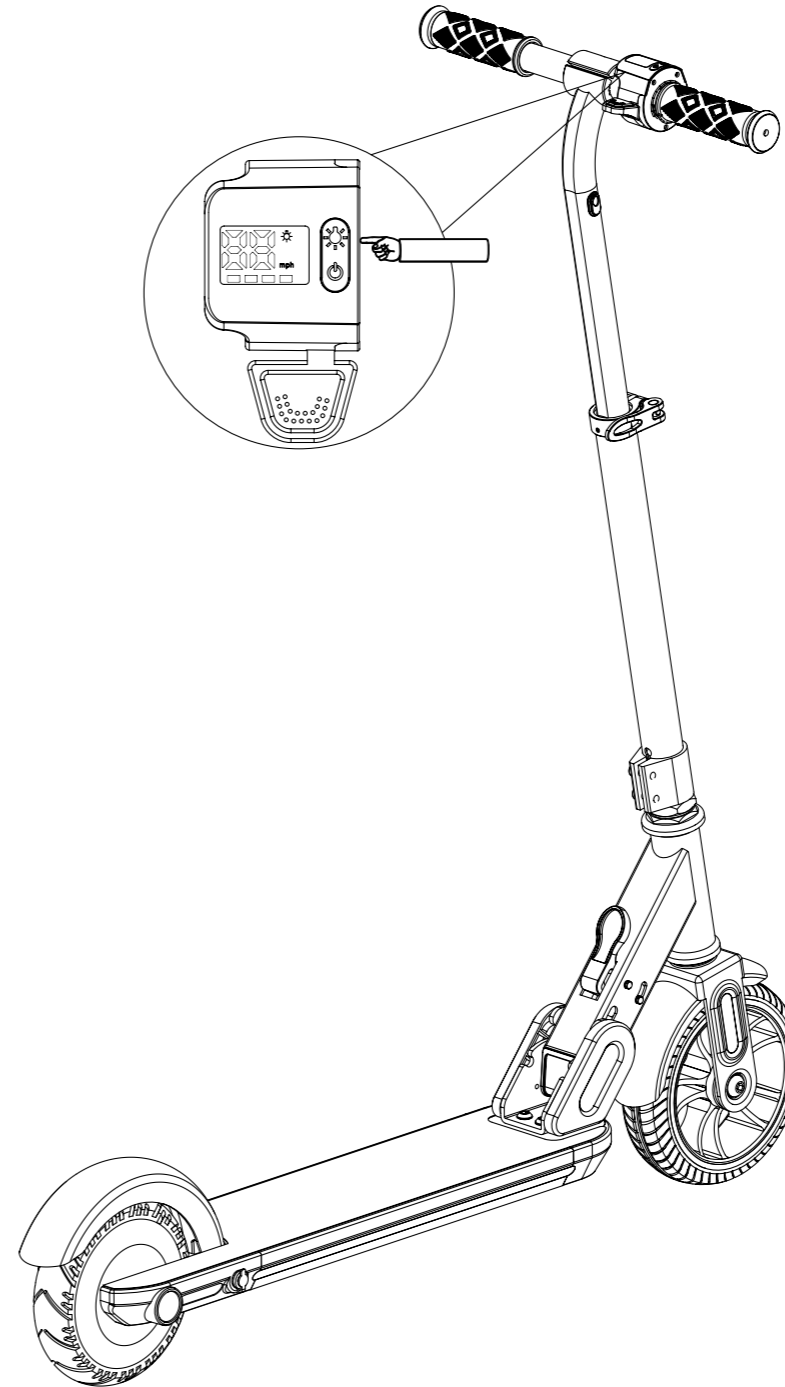

7 Safety Instructions

Helmets and protective gear must be worn while riding.

It is prohibited to ride in motor vehicle lanes, in mixed pedestrian and vehicle areas, and in stagnant water deeper than 2 cm.

Riding with more than one person at a time or carrying a child is not allowed.

Do not ride up or down stairs or escalators.

When encountering speed bumps, elevators, door thresholds, potholes, etc., please reduce your speed or stop using the scooter.

This electric scooter is intended for sports and recreation, not as a primary means of transportation. However, when used in public areas, it does carry the same safety risks as any vehicle. Adhering strictly to the instructions in this manual will help ensure your safety and that of others.

Additionally, you should be aware that riding on public roads or other public spaces, even when following this manual, may expose you to risks from illegal driving or improper operation by others or other vehicles. Just like walking or biking, you can be injured by other vehicles. As with all vehicles, the faster you go, the longer the distance needed to stop. Emergency braking on smooth surfaces may cause the wheels to slip, leading to a loss of balance and a potential fall. Therefore, it is crucial to remain vigilant, maintain a safe speed, and keep a reasonable distance from people and vehicles while riding. Please stay alert and drive slowly when entering unfamiliar terrain.

Please respect pedestrians' right of way while driving. Avoid startling pedestrians, particularly children. When passing pedestrians from behind, provide a clear warning and slow down, passing as far to the left as possible. In countries where vehicles drive on the right, approach pedestrians from the front, stay to the right, and reduce your speed.

Electric scooters must be operated in compliance with applicable standards, as well as national and regional regulations. Please strictly follow the safety requirements outlined in this manual. Our company will not be held liable for any property or personal damage, legal disputes, or other adverse events that may arise from failure to comply with this manual.

Charging the scooter after each use can significantly extend battery life, so try to avoid fully depleting the battery before recharging. Lithium batteries perform best at temperatures around $25\pm 3^{\circ}\text{C}$. As temperatures fluctuate, the discharge efficiency of lithium batteries tends to decrease. For example, in an environment of 0°C , the scooter's range may be reduced to half or less of what it is at 25°C . However, this effect is reversible; as the ambient temperature returns to normal, the battery's discharge efficiency will recover.

Before each ride, perform a basic inspection of the scooter. If you notice any issues such as loose parts, reduced battery life, excessive wear, or unusual noises, stop using the scooter immediately. Contact our customer service team for help and assistance with repairs

8 Folding And Handling

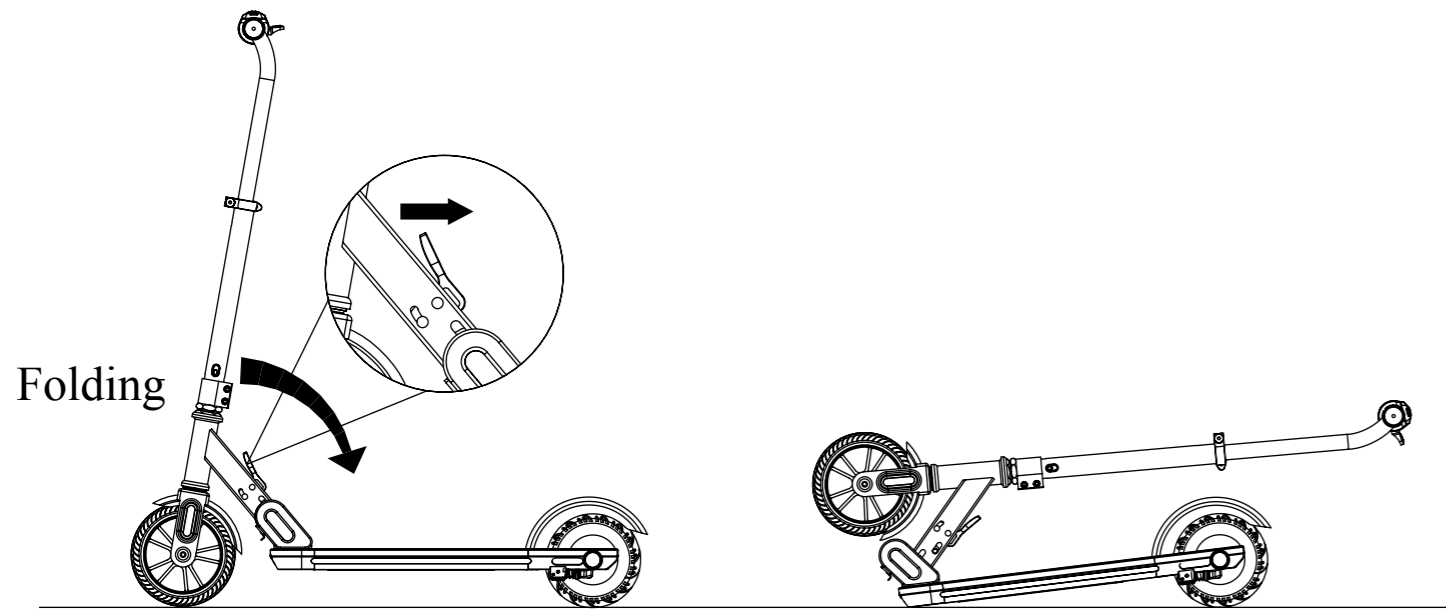

Turn off the power to the scooter, then pull the folding mechanism to fold it.

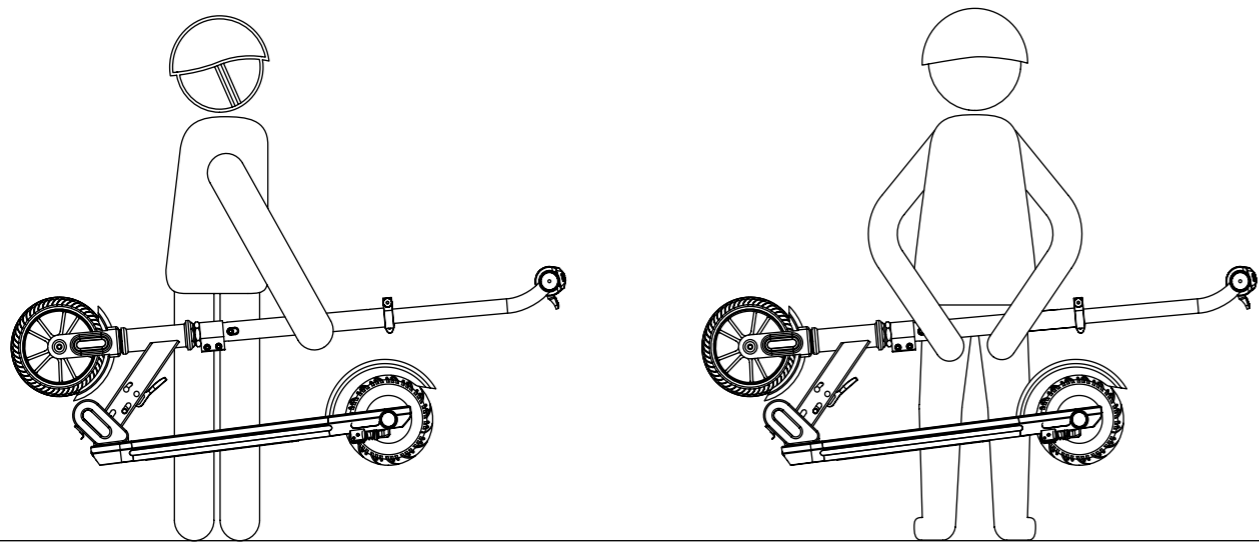

Lift the upright pole of the scooter with one hand or both hands to carry it.

9 Daily Maintenance

Cleaning and Maintenance

If there are stains on the scooter's surface, use a soft cloth dampened with a small amount of clean water to wipe it down. For tougher stains, first use a soft cloth with a bit of toothpaste, then follow up with a damp cloth to clean.

Tips: Do not use alcohol, gasoline, kerosene, or other corrosive and volatile chemical solvents for cleaning, as these can severely damage the scooter's appearance and internal structure. Avoid using a pressure washer to spray, soak, flush, or scrub the scooter. Ensure the scooter is turned off while cleaning, the charging cable is unplugged, and the dust plug for the charging port is securely in place to prevent electric shock or serious malfunctions due to water entering the scooter.

When not in use, store the scooter indoors in a dry, cool place. Avoid prolonged outdoor storage, as exposure to sunlight, excessive heat, or cold environments can accelerate the aging of the scooter's exterior, tire wear, and reduce the lifespan of the battery pack.

Battery Maintenance

Do not expose the battery to temperatures above 50°C or below -20°C (for example, the interior of a car exposed to sunlight during summer).

Do not open or disassemble the battery to avoid the risk of electric shock. Keep the battery away from metal objects to prevent short circuits, which could lead to battery malfunction or injury to the user.

Avoid recharging the battery after it has completely depleted. Instead, try to charge it after each use, as this practice can significantly extend the battery's lifespan. Additionally, when used at room temperature, the battery pack provides longer riding distances and better performance. However, battery performance may decline in environments below 0°C. Typically, at 0°C, the riding distance may be reduced to half or less of what is achievable at room temperature. The riding distance will improve again as the temperature rises.

Tips: A fully charged scooter may exhaust its stored power within about 20 to 90 days of standby. In contrast, an undercharged scooter will lose its power within approximately 20 to 50 days of standby. If the battery is not charged in time, it may lead to over-discharging, causing permanent damage. A damaged battery will not be rechargeable and will not be eligible for warranty service.

Note: Non-professionals are prohibited from disassembling the battery pack, as this could result in serious safety hazards due to electric shock or short circuits.

Product Parameter Table

Performance Index	Project	Parameters
Product size	Fold size (mm)	855X366X317
	Unfold size (mm)	825X366X856
	Box size (mm)	775X175X325
Weight	Maximum load (kg)	70
	Net Weight (kg)	6.5
Riding requirement	Applicable age (years)	5-15
	Applicable height (cm)	100-150
Main parameters of the whole vehicle	Maximum speed (KM/H)	15
	Mileage (KM)	10
	Applicable land type	Hardened pavement, flat asphalt pavement, ramps below 20 degrees, steps not higher than 1cm, trenches not exceeding 1cm
	Waterproof grade	IPX4 (domestic waterproof grade, can be used in drizzle)
Battery parameters	Rated voltage (V)	24
	Charge input voltage (V)	25.2
	Battery capacity (Ah)	2
	Intelligent BMS	Automatic cut-off of equalization / overcharge / undervoltage / overheating
Motor parameters	Rated output power (W)	120
Charging parameters	Rated power (W)	12.5
	Rated input voltage (V)	100-240
	Rated output voltage (V)	25.2
	Rated current (A)	0.5
	Charging time (h)	About 5

Note: Due to the varying capacities of different battery subtypes, specific parameters may differ. The data range provided here is only partial. Please consult your dealer for detailed information.